

TOP-FLOOR

Submersible DRAINAGE pumps

⇒ for clear water



PERFORMANCE RANGE

- Flow rate up to **160 l/min** (9.6 m³/h)
- Head up to **9 m**

APPLICATION LIMITS

- Immersion depth:
 - **1.5 m** with 5 m long power cable
 - **3 m** with 10 m long power cable
- Maximum liquid temperature **+40 °C**
(Maximum liquid temperature +90 °C for a maximum of 3 minutes intermittent service)
- Passage of suspended solids up to **Ø 2 mm**
- Suction down to **2 mm** above ground level
- Continuous service **S1**

CONSTRUCTION AND SAFETY STANDARDS

Complete with **5 m** long power cable

EN 60335-1
IEC 60335-1
CEI 61-150

EN 60034-1
IEC 60034-1
CEI 2-3



CERTIFICATIONS



INSTALLATION AND USE

The **TOP-FLOOR** series is suitable for use with **clear water** that does not contain abrasive particles.

As a result of their ability to drain water to a level of 2 millimetres above ground level, they are suitable for use in domestic emergencies where a small area must be drained to the lowest level possible.

PATENTS - TRADE MARKS - MODELS

- Registered Community Design n° 342159-0011

OPTIONALS AVAILABLE ON REQUEST

- Pumps with float switch
- Special mechanical seal
- Pumps with a **10 m** long power cable
 - ⇒ N.B. Standard EN 60335-2-41 states that the power cable must be 10 m long for outdoor applications
- Other voltages or 60 Hz frequency

GUARANTEE

2 years subject to terms and conditions

CHARACTERISTIC CURVES AND PERFORMANCE DATA

50 Hz n= 2900 1/min

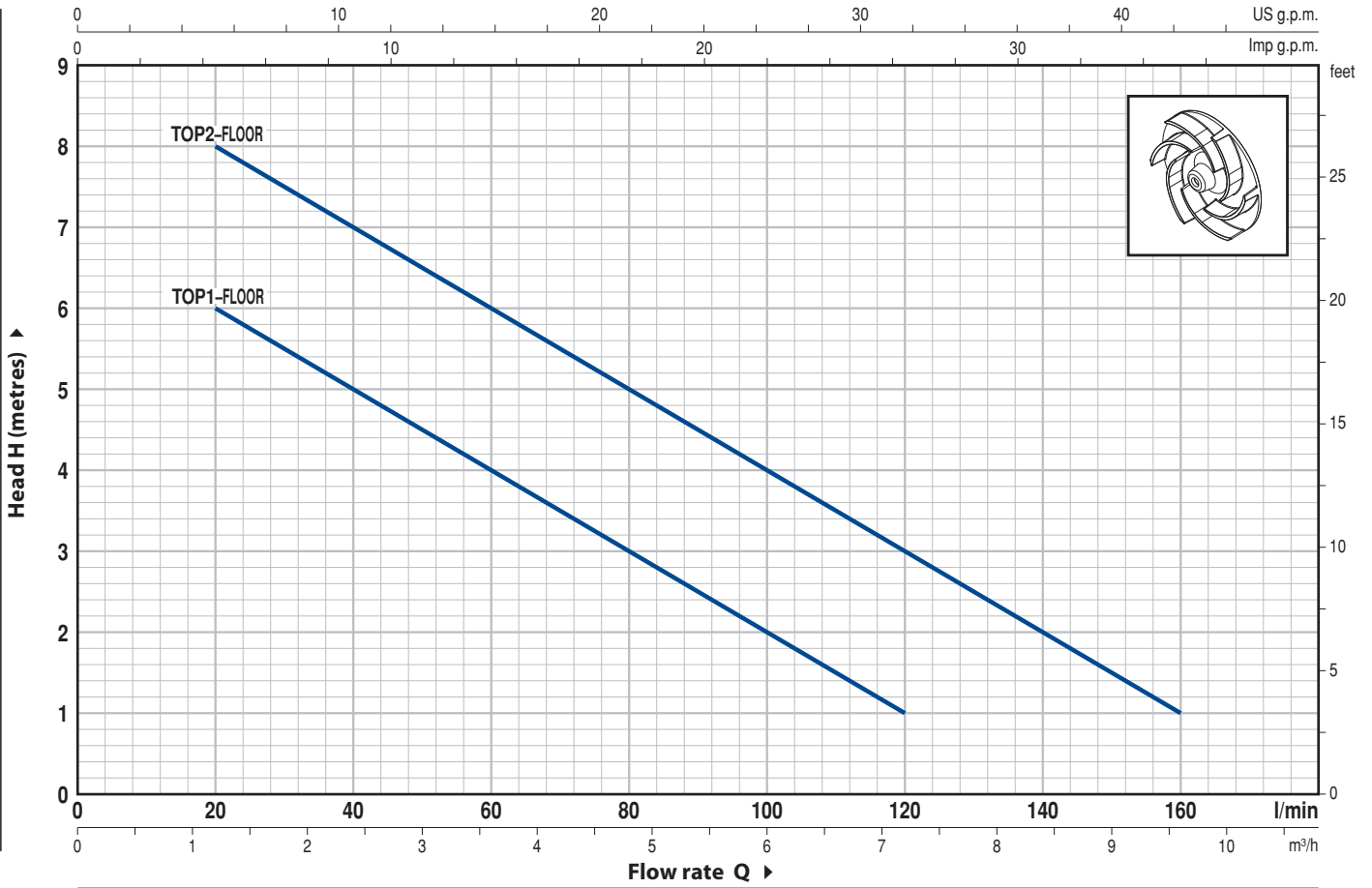

MODEL	POWER		Q	0	1.2	2.4	3.6	4.8	6.0	7.2	8.4	9.6
	kW	HP		0	20	40	60	80	100	120	140	160
Single-phase			l/min									
TOP1-FLOOR	0.25	0.33	H metres	7	6	5	4	3	2	1		
TOP2-FLOOR	0.37	0.50		9	8	7	6	5	4	3	2	1

Q = Flow rate H = Total manometric head

Tolerance of characteristic curves in compliance with EN ISO 9906 App. A.

TOP-FLOOR

POS.	COMPONENT	CONSTRUCTION CHARACTERISTICS	
1	PUMP BODY	Technopolymer	
2	SUCTION FILTER	Technopolymer	
3	SUCTION PLATE	Stainless steel AISI 304	
4	DIFFUSER	Technopolymer	
5	IMPELLER	Noryl GFN2V	
6	MOTOR CASING	Stainless steel AISI 304	
7	MOTOR CASING PLATE	Stainless steel AISI 304	
8	MOTOR SHAFT	Stainless steel EN 10088-3 - 1.4104	
9	SHAFT WITH DOUBLE SEAL AND OIL CHAMBER		
	<i>Seal</i>	<i>Shaft</i>	<i>Materials</i>
	<i>Model</i>	<i>Diameter</i>	<i>Stationary ring</i> <i>Rotational ring</i> <i>Elastomer</i>
	AR-12R	Ø 12 mm	Ceramic Graphite NBR
10	LIP SEAL	Ø 12 x Ø 19 x H 5 mm	
11	BEARINGS	6201 ZZ / 6201 ZZ	
12	CAPACITOR		
	<i>Pump</i>	<i>Capacitance</i>	
	<i>Single-phase</i>	<i>(230 V or 240 V)</i>	<i>(110 V)</i>
	TOP1-FLOOR	6.3 µF 450 VL	16 µF 250 VL
	TOP2-FLOOR	10 µF 450 VL	16 µF 250 VL
13	ELECTRIC MOTOR		
	<ul style="list-style-type: none"> - Single-phase 230 V - 50 Hz with thermal overload protector built-in to the winding - Insulation: F class - Protection: IP 68 		
14	HANDLE ASSEMBLY (resin sealed)		
	Complete with 5 metre long "H07 RN-F" power cable with Schuko plug		
15	HOSE CONNECTOR WITH UNION		
	Ø 25 mm hose connection for TOP1 - FLOOR Ø 35 mm for TOP2 - FLOOR		

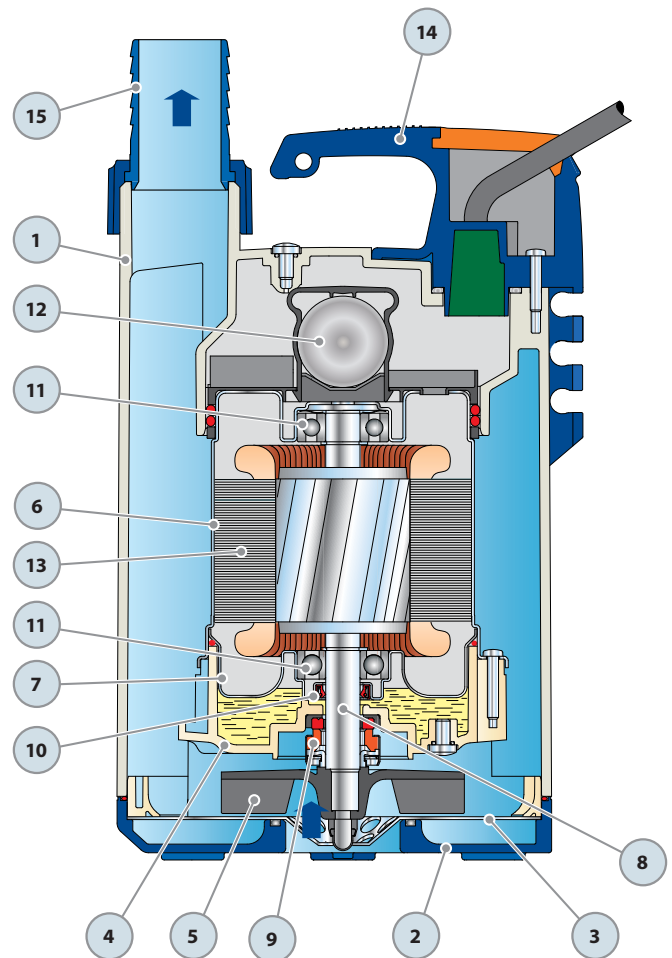

DIMENSIONS AND WEIGHT

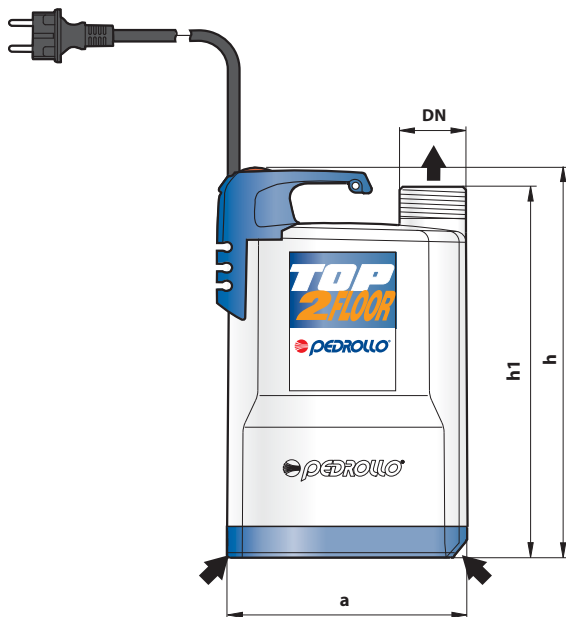

Typical installation

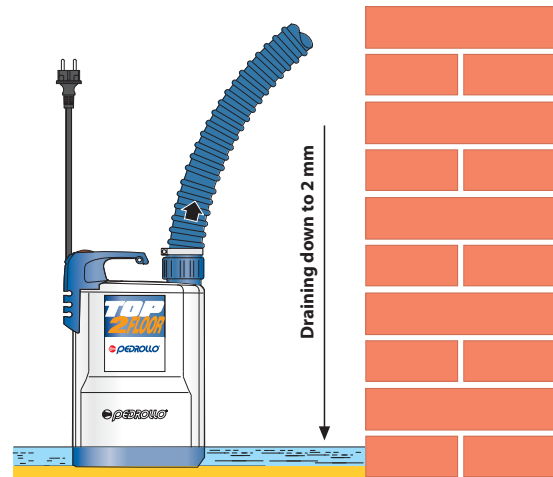

MODEL	PORT DN	DIMENSIONS mm			Minimum drying level	kg
		a	h	h1		
Single-phase	1 1/4"	152	257	237	2 mm	4.3
TOP1-FLOOR						5.0
TOP2-FLOOR						

ABSORPTION

MODEL	VOLTAGE (single-phase)		
	230 V	240 V	110 V
Single-phase			
TOP1-FLOOR	1.3 A	1.3 A	3.0 A
TOP2-FLOOR	2.0 A	2.0 A	5.3 A

PALLETIZATION

MODEL	GROUPAGE			CONTAINER		
	n° pumps	H (mm)	kg	n° pumps	H (mm)	kg
Single-phase						
TOP1-FLOOR	96	1260	430	168	2100	739
TOP2-FLOOR	96	1260	500	168	2100	862

