

# MICRA

## 3" SUBMERSIBLE PUMPS



### DOMESTIC WATER SUPPLY

Centrifugal type. Directly coupled pump and motor with rigid coupling. Impellers and thrust rings in Noryl and diffusers in self-lubricating polyacetyl. Pump liner, shaft and coupling, strainer and cable sheath in stainless steel. Base support and head in brass with check valve incorporated in head. Submersible asynchronous two-pole motor made entirely of AISI 304 stainless steel with brass bearings. Squirrel cage rotor in copper mounted on Kingsbury thrust block. Cooling of the thrust bearing assembly and the bushings is provided by water, thereby eliminating the risk of oil contamination. Canned-type stator in an airtight casing made of AISI 304L stainless steel. The automatic reset thermal protection device is integral with the motor.

clean, free of solid or abrasive contaminants, non-viscous, chemically neutral, close to the properties of water.  
da 0° C a +35° C.

40 g/m<sup>3</sup>.

IP 68.

F.

20/h.

MICRA 50 - 1 m.

MICRA 75 - 1,2 m.

MICRA 100 - 1,4 m.

Ready-to-install kit available including single phase electric pump with 15m cable and control panel and double capacitor control panel.

## TECHNICAL DATA

MODEL	CODE	ELECTRICAL DATA							HYDRAULIC DATA (n = 2800 1/min)										
		VOLTAGE 50 Hz	P1 MAX kW	P2 NOMINAL		In A	CAPACITOR		Q m <sup>3</sup> /h l/min	H (m)									
				kW	HP		µF	Vc		0,3	0,6	0,9	1,2	1,5	1,8	2,1	2,4	2,7	
MICRA 50 M	0090114	1x230V ~	0,65	0,37	0,5	3,3	12	450	45	41	38	35	31	27	21	14	6		
MICRA 75 M	0090418	1x230V ~	0,95	0,55	0,75	5,1	16	450	68	64	59	54	48	42	33	23	11		
MICRA 75 T	0090618	3x400V ~	0,9	0,55	0,75	1,9	-	-	68	64	59	54	48	42	33	23	11		
MICRA 100 M	0090817	1x230V ~	1,2	0,75	1	6,1	20	450	90	84	78	72	65	56	44	30	14		
MICRA 100 T	0090944	3x400V ~	1,15	0,75	1	2,4	-	-	90	84	78	72	65	56	44	30	14		
MICRA 50 M + 15 mt. Cable + Control Box*	0090116	1x230V ~	0,65	0,37	0,5	3,3	12	450	45	41	38	35	31	27	21	14	6		
MICRA 75 M + 15 mt. Cable + Control Box*	0090419	1x230V ~	0,95	0,55	0,75	5,1	16	450	68	64	59	54	48	42	33	23	11		
MICRA 100 M + 15 mt. Cable + Control Box*	0090818	1x230V ~	1,2	0,75	1	6,1	20	450	90	84	78	72	65	56	44	30	14		

\* Double capacitor booster control panel to optimize the starting torque

## DIMENSIONS AND WEIGHTS

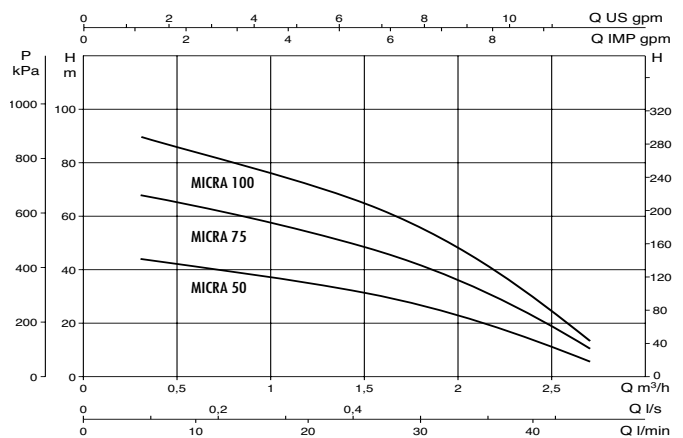
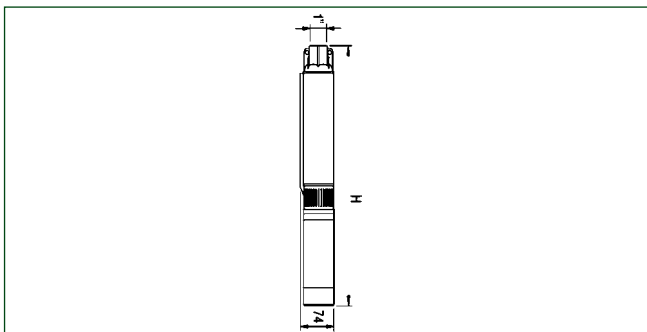

MODEL	Ø	H	DNM	PACKAGING DIMENSIONS		WEIGHT KG
				Ø	H	
MICRA 50	74	930	1"	86	1150	9
MICRA 75	74	1145	1"	86	1350	10,2
MICRA 100	74	1390	1"	86	1600	13,6